

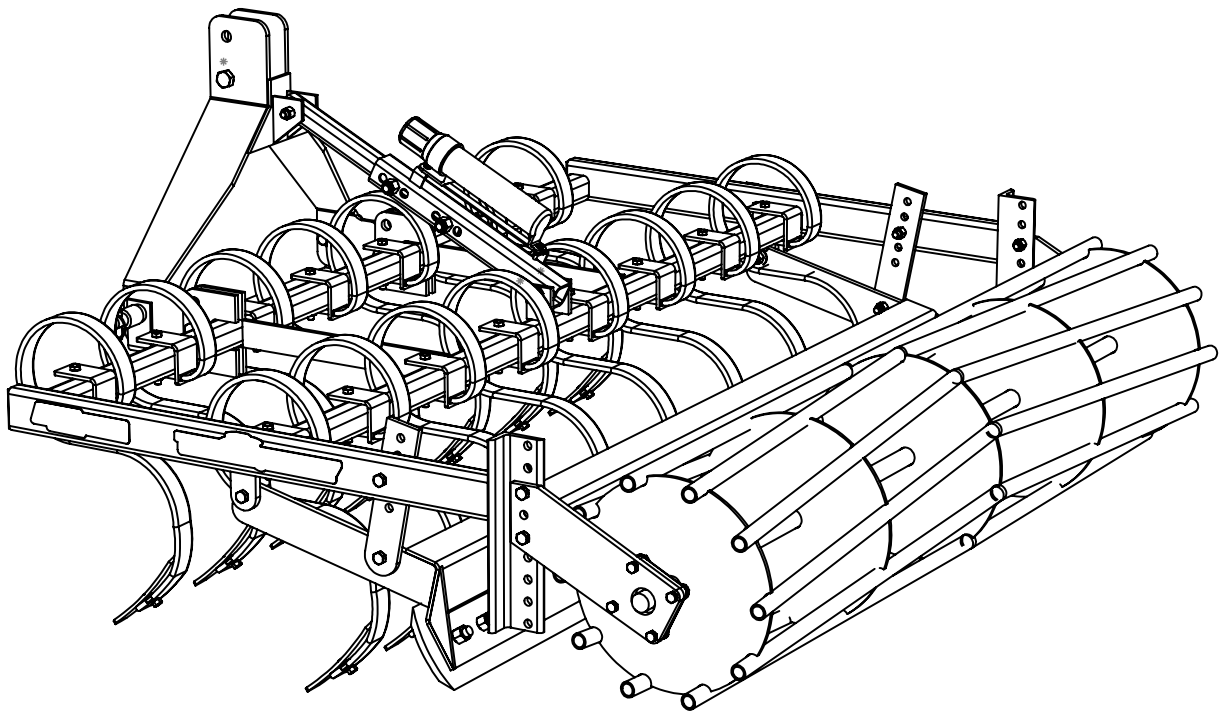

Operator's / Parts Manual



MK Martin Enterprise Inc.
3950 Steffler Rd Elmira, ON, Canada N3B 2Z3

Tel: 519-664-2752
Toll Free: 1-855-664-2752
Fax: 519-664-3695
E-mail: sales@mkmartin.ca
www.mkmartin.ca



Rev:18-1

Table of Contents

• Warranty	-----	2
• Registration	-----	3
• Safety	-----	5-6
• Decals	-----	7
• Assembly	-----	8
• Operation	-----	8
• Sign Off Form	-----	9
• Shank Spacing	-----	10-11
• Track Curry Parts	-----	12-13
• Track Curry Wing Parts	-----	14
• Notes	-----	15
• Sprinkler System Parts	-----	16-17
• Sprinkler Operation	-----	18-19
• Maintenance	-----	20
• Bolt Torque	-----	20



3950 Steffler Rd. • Elmira • Ontario, Canada • N3B 2Z3 • Email : sales@mkmartin.ca • Fax : (519)-664-3695 • Tel : (519)-664-2752

Warranty

Effective on products retailed on or after November 1, 2017

Two Year Limited Consumer Warranty

Five Year Limited Consumer Warranty on Gearboxes

90 Day Limited Commercial Warranty including Gearboxes

Commercial includes rental and industrial applications.

Warranty begins at the time of customer delivery and is activated upon warranty registration receipt at MK Martin Enterprise Inc.

Warranty coverage is null and void unless the Warranty Registration form has been completed in full and is on file at MK Martin Enterprise Inc.

Keep your registration copy in a safe place, it is required as proof of warranty activation.

This new and unused product is warranted by MK Martin Enterprise Inc. to be free from defects in material and workmanship under normal use and regular service as described in the owner's manual, for a consumer period of 2 years and 5 years for gearboxes, from the date of delivery, and commercial period of 90 days, including gearboxes, from the date of delivery. Warranty is limited to the replacement of parts and / or repair of the product.

If issues develop within the warranty period with the product, contact the local dealer from which you purchased the unit. Only MK Martin authorized dealers may make repairs to the product or affect the replacement of defective parts, unless otherwise approved by MK Martin. Repairs / replacement will be done at no charge within a reasonable time after the receipt of the product.

This warranty does not cover the following items:

1. Normal replacement of service items.
2. Normal maintenance or adjustments.
3. Machines or parts lost or damaged during shipment,
4. Accessory items / parts not supplied by MK Martin
5. Damages resulting from:
 - misuse, negligence, accident, theft or fire
 - use of improper or insufficient fuel, fluids or lubricants
 - use of after market parts or accessories, unless approved by MK Martin
 - modifications, alteration, tampering or improper repair
 - any device or accessories installed by other than an authorized dealer.
6. Tires are covered by the manufacturer of the tire and the warranty period specified by that manufacturer. **Please contact the tire manufacturer for warranty on these items.**

MK Martin Enterprise Inc. shall not, in any event, be liable for any losses, damages or costs; to include profits, travel, transportation, pick up, delivery, towing cost, tow vehicle, loss of use, whether special, incidental, consequential or otherwise, in any way. Unit or parts are returned at the customer's expense.

Include a copy of your completed Warranty Registration form with any claim as proof of warranty activation.

There are no warranties, expressed or implied, other than those specified herein. No agent, employee or other person has any authority to vary any of the foregoing provisions.

Warranty coverage is null and void unless the Warranty Registration form has been completed in full and is on file at MK Martin Enterprise Inc. Warranty begins at the time of customer delivery and is activated upon Warranty Registration receipt at MK Martin Enterprise Inc.

M K Martin Enterprise Inc
3950 Steffler Rd
Elmira ON CA N3B 2Z3

Purchaser's warranty protection is valid only when this completed form or a copy of this form is on file at M K Martin Enterprise Inc. By filling out this form the purchaser has acknowledged delivery of equipment and owner's / operator's manual and has accepted the condition of the equipment.

Date of delivery to purchaser -----

Type of Equipment -----

Model # ----- **Serial #** -----

Retailer's Signature Indicates

- *Equipment was properly assembled as directed by manufacturer*
- *Equipment was tested for functionality and operates properly*
- *Purchaser was instructed in safe and proper operating procedures*
- *Warranty was explained to purchaser*
- *Purchaser was given the operators manual*

Retailer

Signature -----

Company -----

Address -----

Purchaser's signature indicates

- *Acceptance of equipment fully assembled*
- *Received operator's manual*
- *Clearly understands conditions of warranty*
- *Received instructions of safe and proper operation of equipment*

Purchaser

Signature -----

Company -----

Mailing address -----

City ----- **Prov/State** ----- **Postal Code/Zip** -----

Available phone number -----

Warranty is valid only when it has been received by manufacturer at address above

Warranty Registration

Please Cut and Return to M K Martin Enterprise Inc

Fold And Tape here

Do not tape all edges or use staples

Fold Here

**Postage
Stamp**

**M K Martin Enterprise Inc
3950 Steffler Rd
Elmira ON CA N3B 2Z3**

Safety

Take Note! This safety symbol is found throughout this manual to call your attention to instructions involving yourself and others working around the machine.

- **Failure to follow these instructions can result in injury or death**



This symbol means

- **Attention!**
- **Become Alert!**
- **Your Safety is involved!**

Signal words are used in this manual.

Caution: Indicates a potential hazardous situation that may result in injury.

Warning: Indicates a hazardous situation that could result in serious injury or death.

Danger: Indicates a hazardous situation that needs to be avoided. It is you the operator that needs to be aware of these dangers.

If you have any questions not answered in this manual please contact your dealer or

M K Martin Enterprise Inc
3950 Steffler Rd
Elmira On Ca N3B 2Z3

Tel: 519-664-2752
1-855-664-2752
Fax: 519-664-3695
e-mail sales@mkmartin.ca

www.mkmartin.ca



Safety -- It,s in your interest!

You are responsible for the safe operation and maintenance of your Track Curry.

You must ensure that you and anyone else who operate the Track Curry are properly trained to operate it.

Annually refresh yourself and all other operators on the safe use of the Track Curry.



Warning! Keep hands and feet away from the Track Curry at all times during operation. Keep bystanders at a safe distance.



Warning! Do not operate the Track Curry in places that have rocks and other debris. Do not operate on steep slopes that may upset the tractor.



Warning! Do not operate at high speeds.



Warning! Do not attempt to repair or adjust the equipment while the 3 point hitch is holding the Track Curry up. (Place a block under the equipment to hold it up.)



Warning! Do not allow any riders on the tractor or the Track Curry!

Decal Locations

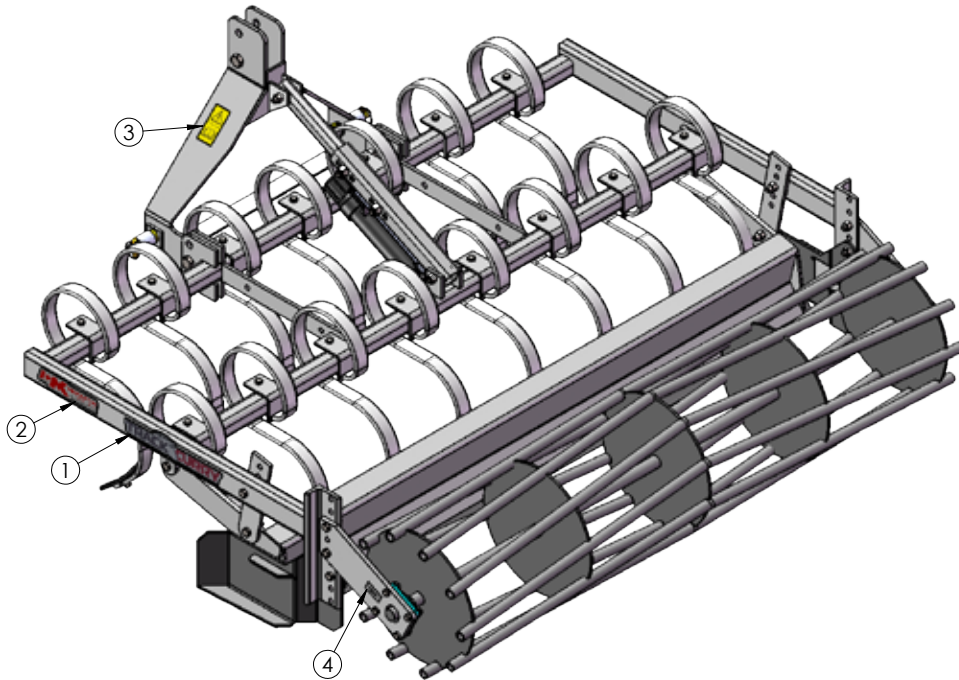

Part #1 Series decal x2



Part #2

MK logo made in canada



Part #3

Before operating machine, carefully read the instruction manual

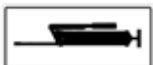

#4 - Grease x2

Assembly

This unit is usually shipped with the cultivator teeth removed.

1. Bolt the large “A” frame brace to the frame and the small brace to the top of the “A” frame using 1/2” bolts and nylon locknuts.
2. Use one 5/8” bolt to couple brace pieces together and allowing 5” of movement, this allows the machine to “float”.
3. By using a second 5/8” bolt at the other end of the slot the brace length can be fixed.
4. Install the teeth and space them as shown on the following pages according to the width of your Track Curry.
5. Adjust the leveler blade and the rear drum height to suit your needs.
6. The Track Curry is designed to handle Cat #1 ASAE Quick Coupler and Cat #1 Free Link and JD “I” Match.

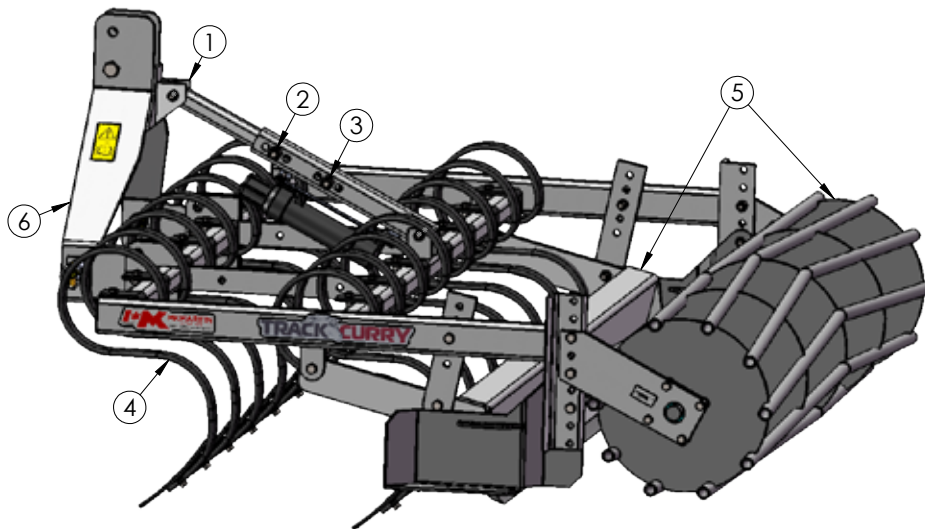

Operation

The Track Curry is designed to renovate and condition horse arenas and tracks in a single pass. Two rows of heavy duty S-tine shanks loosen and cultivate, an adjustable bar levels the soil and a 12” diameter roller gauge controls the depth and packs the soil. Resulting in a firm yet giving surface for secure footing.

Four Models

- 5' Track Curry *with* 13 Shanks (18-33) hp
- 6' Track Curry *with* 15 Shanks (22-39) hp
- 7' Track Curry *with* 17 Shanks (24-47) hp
- 8' Track Curry *with* 19 Shanks (30-53) hp

Shank size: 1 1/4x22 c/w reversible points

Leveler Bar 1/2x6” double-beveled

Shank Spacing

5' - 13 Shanks

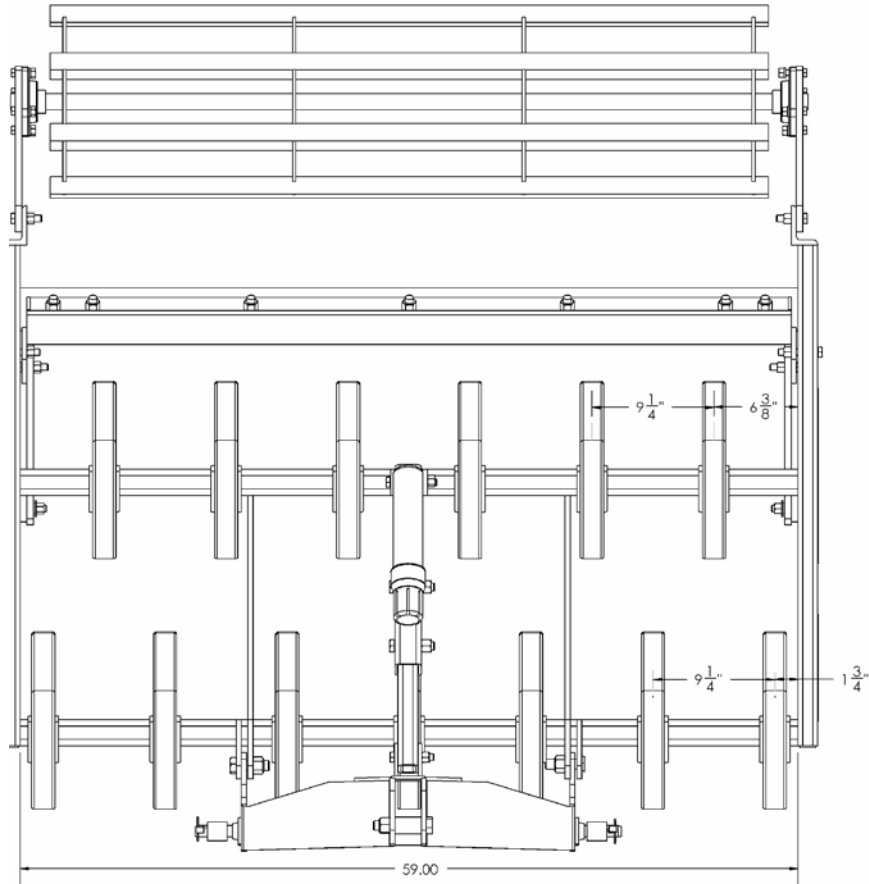

6' - 15 Shanks

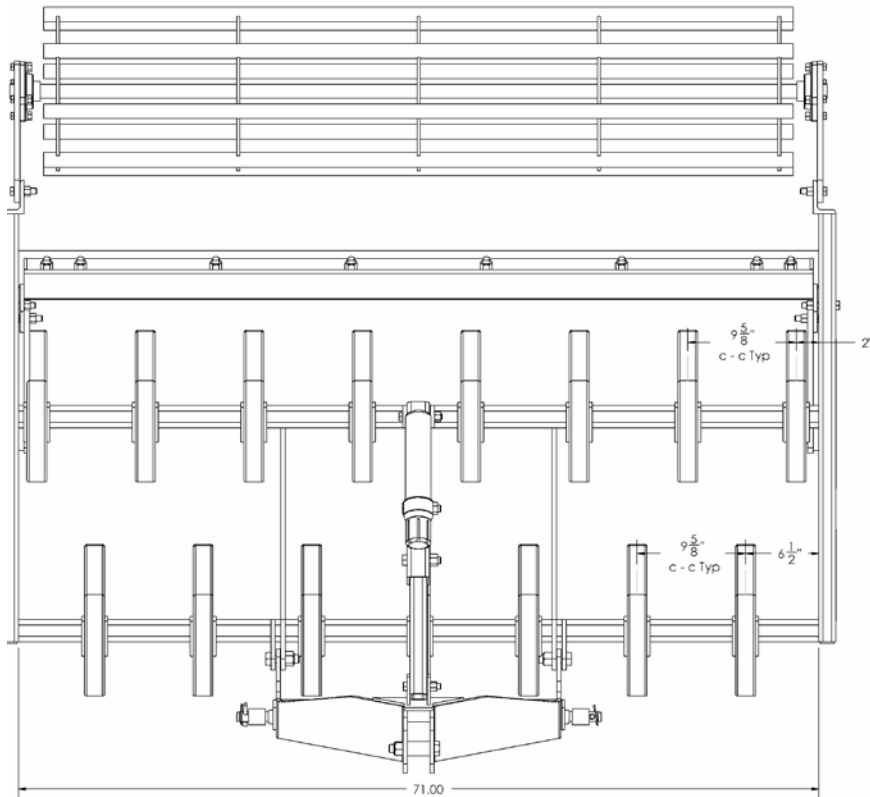

Shank Spacing

7' - 17 Shanks

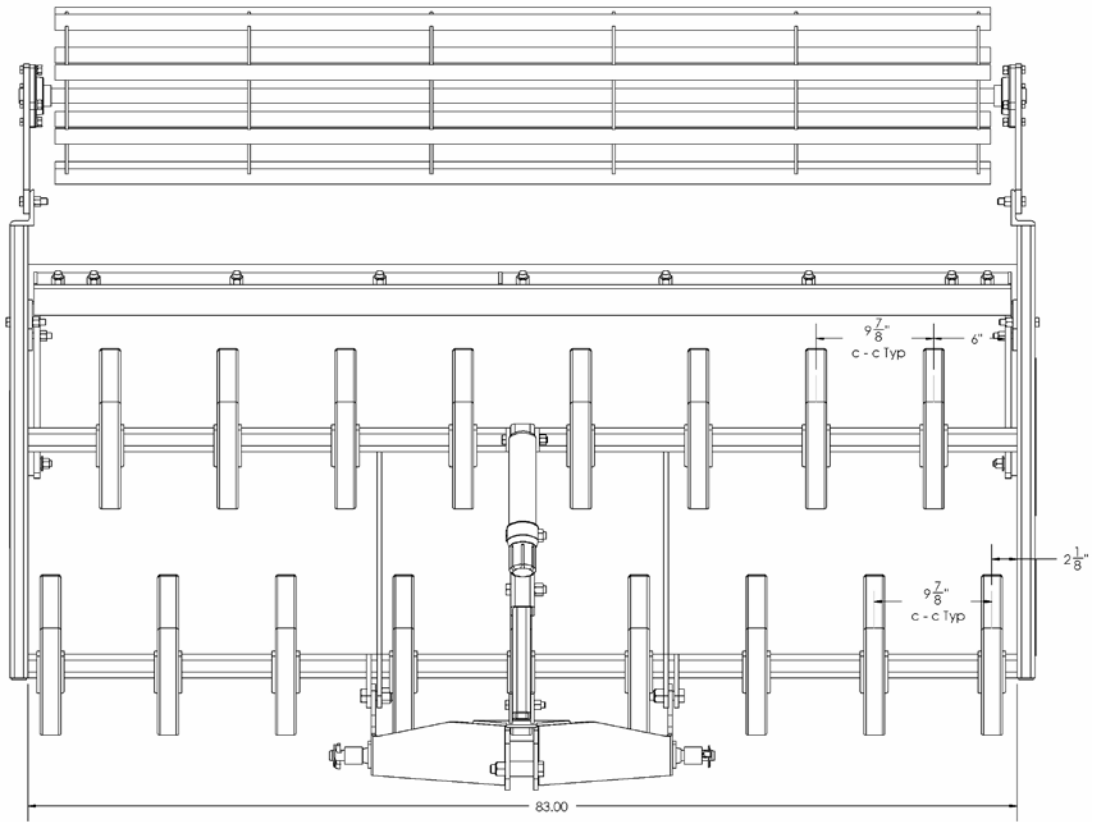

8' - 19 Shanks

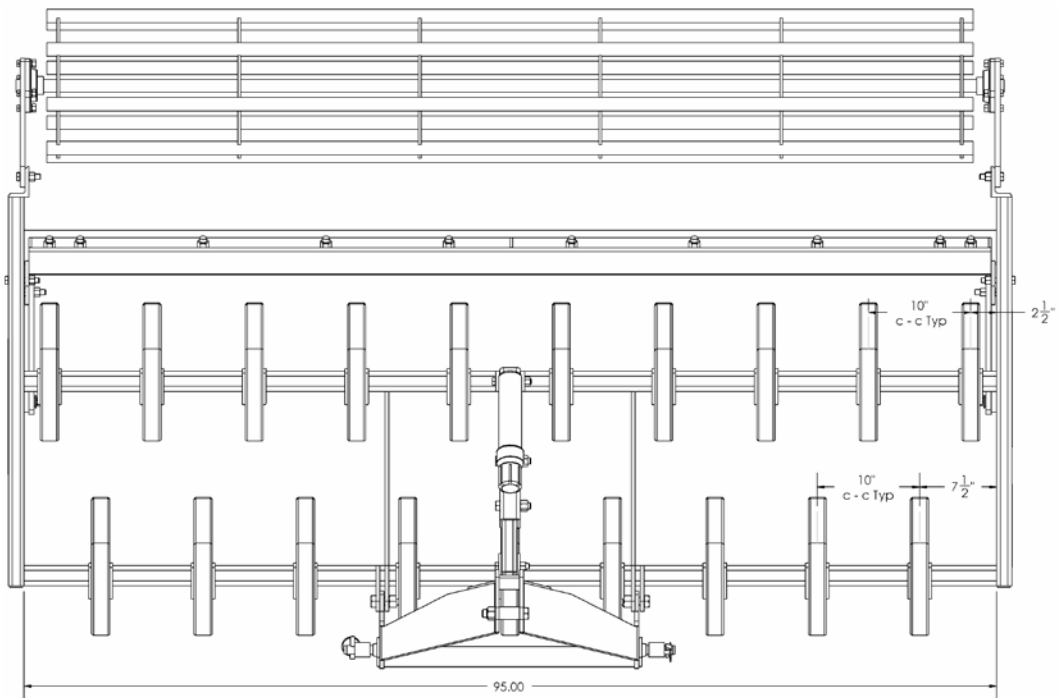

Track Curry Parts

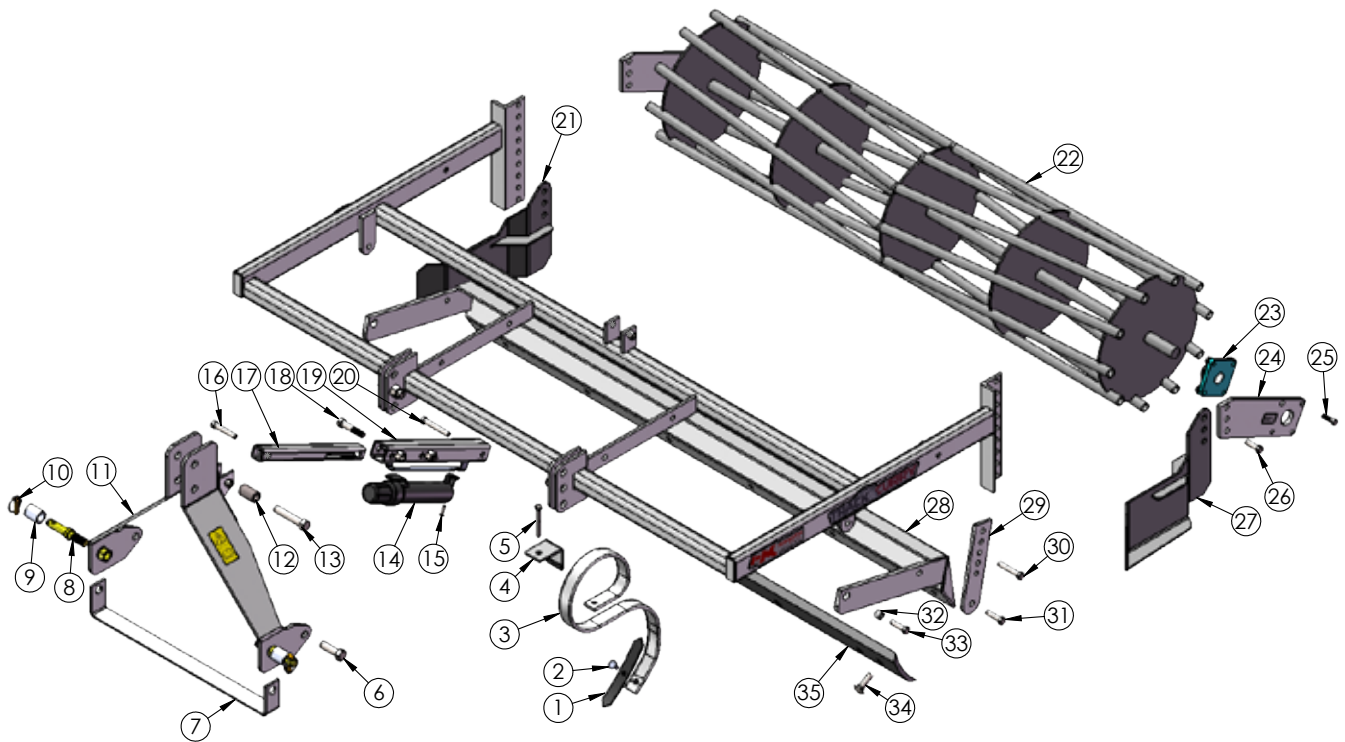

Item #	Part #	Description	TC-5 Qty	TC-6 Qty	TC-7 Qty	TC-8 Qty
1-2	54068	Cultivator Point - Bolt 5'	13	15	17	19
3	54069	"S" Tine	13	15	17	19
4	54071	Tine Clamp	13	15	17	19
5	OL	Bolt 7/16x4 c/w In	13	15	17	19
6	OL	Bolt 3/4x2 1/2 c/w In	2	2	2	2
7	30001	"A" Frame Stiffener	1	1	1	1
8	53061	Cat #1 Hitch Pin	2	2	2	2
9	30161	Lower Quick Hitch Bushing	2	2	2	2
10	OL	Lynch Pin	2	2	2	2
11	30036	"A" Frame	1	1	1	1
12	30162	Bushing Top Link	1	1	1	1
13	OL	Bolt 3/4x4 c/w In	1	1	1	1
14	52649	Op Manual Tube	1	1	1	1
15	OL	Flange bolt/Nut 1/4x3/4	2	2	2	2
16	OL	Bolt 1/2x3 c/w In	1	1	1	1
17	30006	Upper Top Brace	1	1	1	1
18	OL	Bolt 5/8x3 c/w In	2	2	2	2
19	30016	Lower Top Brace	1	1	1	1

Track Curry Parts

Item #	Part #	Description	TC-5 Qty	TC-6 Qty	TC-7 Qty	TC-8 Qty
20	OL	Bolt 1/2x3 1/2 c/w In	1	1	1	1
21	53315	Spill Plate	1	1	1	1
22	52635	Gauge Drum 5'	1			
	52630	Gauge Drum 6'		1		
	52634	Gauge Drum 7'			1	
	52632	Gauge Drum 8'				1
23	54070	Bearing	2	2	2	2
24	30009	Bearing Bracket	2	2	2	2
25	OL	Bolt 7/16x1 1/2 c/w In	8	8	8	8
26	OL	Bolt 1/2x2 c/w In	6	6	6	6
27	53316	Spill Plate	1	1	1	1
28	30037	Leveler Frame 5'	1			
	30038	Leveler Frame 6'		1		
	30039	Leveler Frame 7'			1	
	30040	Leveler Frame 8'				1
29	30011	Leveler Adjuster Bar	2	2	2	2
30	OL	Bolt 1/2x3 c/w In	2	2	2	2
31	OL	Bolt 1/2x2 c/w In	2	2	2	2
32	30014	Spacer	2	2	2	2
33	OL	Bolt 1/2x2 c/w In	2	2	2	2
34	OL	Carriage Bolt 5/8x2 c/w In	7	8	9	10
35	52787	Leveler Wear Bar 5'	1			
	53089	Leveler Wear Bar 6'		1		
	53090	Leveler Wear Bar 7'			1	
	53918	Leveler Wear Bar 8'				1

Note:
c/w = Complete With
OL = Obtain Locally
In = Locknut

Track Curry Opt. Wing Parts

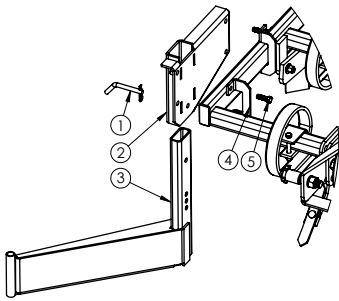

Item #	Part #	Description	Qty
1	53748	1/2 bent pin	1
2	53187	Wing Holder	1
3	53192	Wing Blade	1
4	53193	Wing Clamp	2
5	OL	Bolt 1/2 x 1 1/2 c/w lw, n	4

Track Curry Opt. Scarifier Bar Parts

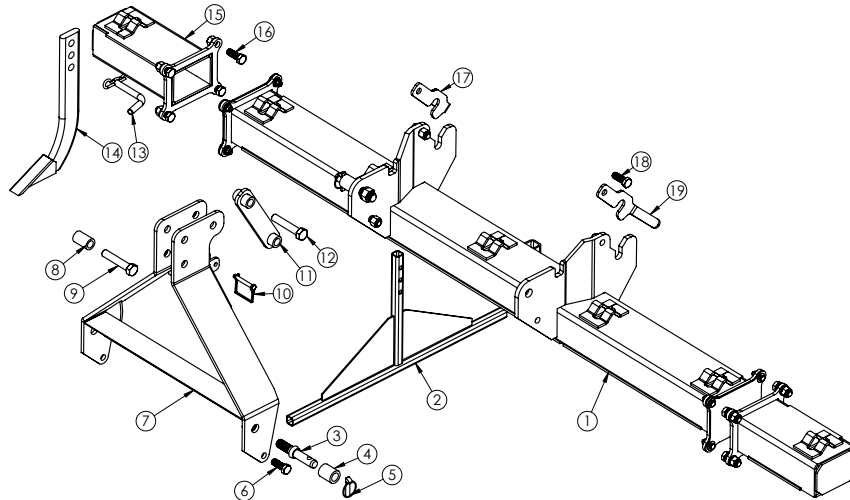

Item #	Part #	Description	TCSA5 Qty	TCSA6 Qty
1	54074	5ft Main Beam	1	
	36279	6ft Main Beam		1
2	36286	Stand	1	1
3	53061	Cat. 1 Lift Pins	2	2
4	30161	Bushing	2	2
5	52656	Lynch Pin	2	2
6	OL	Bolt 5/8 x 1 3/4 c/w ln	2	2
7	36280	A Frame	1	1
8	30162	Bushing	1	1
9	OL	Bolt 3/4 x 4 c/w ln	1	1
10	52705	PTO Pin	1	1
11	36281	Top Link	1	1
12	OL	Bolt 3/4 x 4 c/w ln	1	1
13	50219	Bent Hitch Pin	4-6	5-7
14	54064	Shank	4-6	5-7
15	36282	Scarifier Extension (TCSE12)	2	2
16	OL	Bolt 5/8 x 1 3/4 c/w ln	8	8
17	36271	Latch Right	1	1
18	36270	Latch Left	1	1
19	OL	Bolt 5/8 x 1 3/4 c/w ln	2	2

Track Curry Opt. Sprinkler System Parts

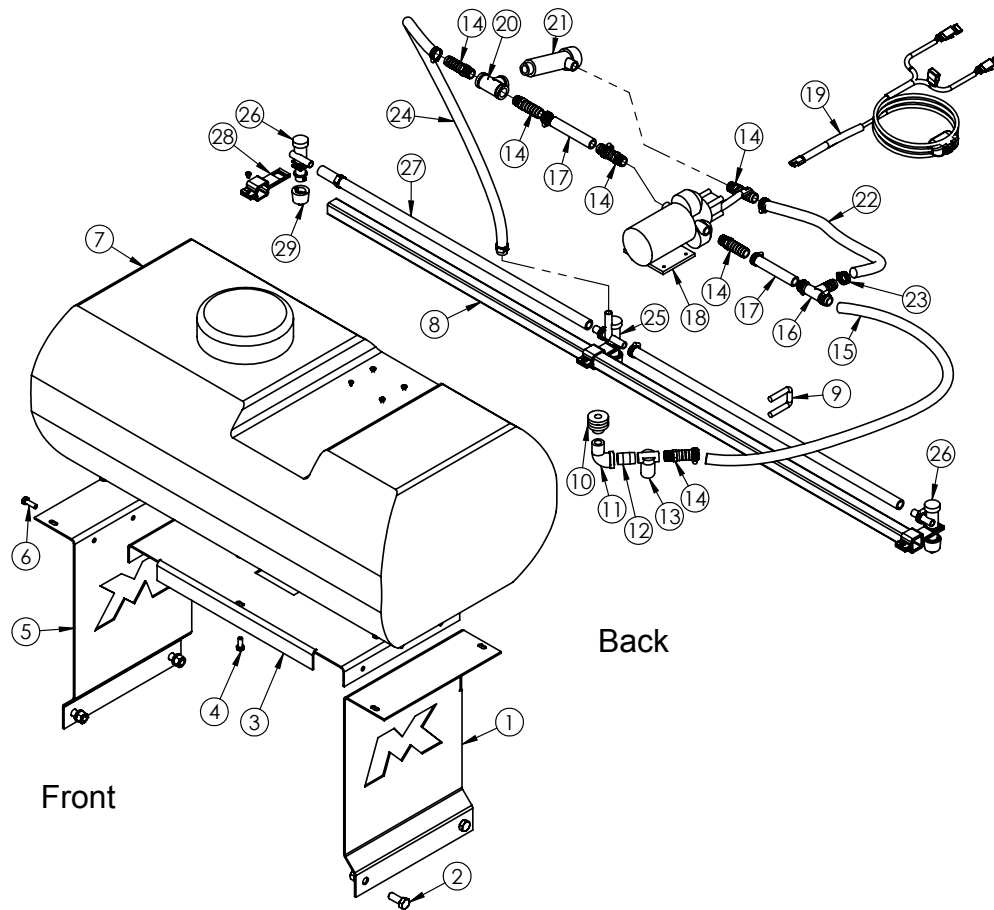

Item #	Part #	Description	Qty
1	60000	Left side leg	1
2	OL	Bolt 1/2 x 1 1/4 c/w lw, n	4
3	60002	Tank support	1
4	OL	Bolt 5/16 x 3/4 c/w lw	6
5	60001	Right side leg	1
6	OL	Bolt 5/16 x 1 c/w lw, n	6
7	54083	Tank	1
8	60004	Boom tube	1
9	OL	UBolt 3/8-16 x 1-1/16 x 1-3/4 leg Sq c/w fw, lw, n	2
10	54084	Tank fitting	1
11	54085	1/2 Street Elbow	1
12	54086	1/2 Close Nipple	1
13	54087	Line strainer	1
14	54100	1/2 Barb nipple	1 (x6)
15	60009	Suction hose	1
16	54099	1/2 Tee	1
17	60011	Hose	1 (x2)
18	54089	Pump	1

Track Curry Opt. Sprinkler System Parts

Item #	Part #	Description	Qty
19	54075	Battery cable	1
20	54101	1/2 Tees	1
21	54091	Relief valve	1
22	60010	Bypass line	1
23	54092	Hose Clamp	14
24	60008	Boom supply hose	1
25	54102	Nozzle body triple	1
26	54103	Nozzle body 1 HB	2
27	60007	Hose	2
28	54104	Boom clamp	3
29	54105	Nozzle	3

Sprinkler System motor Parts

SERVICE KITS

Kits are readily available to repair standard 2088 series pumps. Repair kits include simple illustrated instructions allowing easy installation. To insure that the correct kit is received the model number and all name plate data must be included with the order. Contact a SHURflo distributor or SHURflo directly to order the necessary repair kit.

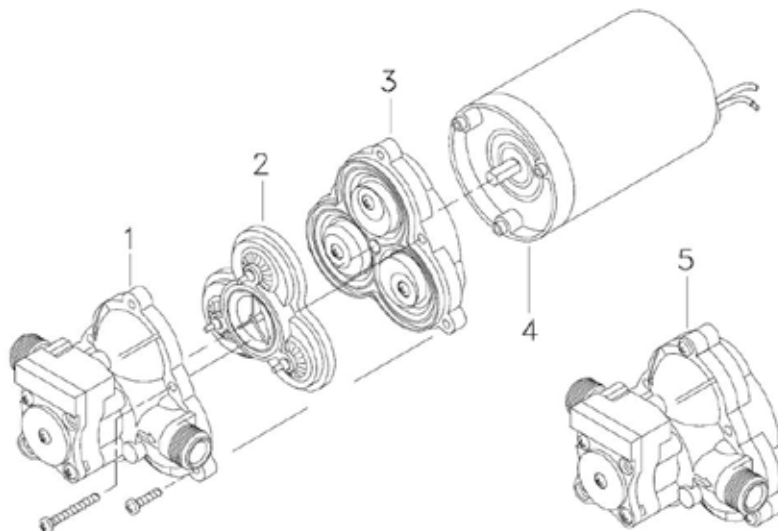

1	Switch / Check valve and Upper Housing Kit (Replaces all previous switch designs)
2	Valve plate assembly
3	Diaphragm / Drive assembly
4	Motor
5	Complete Pump Head assembly (includes parts # 1,2,3) (Replaces all previous switch designs)

Sprinkler System Operation

CAUTION: “Intermittent Duty” is defined as; operated and/or frequently started within a period of time that would cause the motor to reach its maximum thermal limits. Once the maximum thermal limit is obtained, the motor must be allowed to return to ambient temperature before resuming operation.

CAUTION: DO NOT operate the pump at pressures which causes the motor to exceed the amperes rating indicated on the name plate. Various pump models are equipped with thermal breakers to interrupt operation due to excessive heat. Once the temperature of the motor is within proper limits it will automatically reset, and the pump will start operation without warning.

CAUTION: To prevent electrical shock, disconnect power before initiating any work. In the case of pump failure, the motor housing and/or the pumped fluid may carry high voltage to components normally considered safe.

PRESSURE SWITCH OPERATION

The pressure switch reacts to outlet pressure, and interrupts power at the preset shut-off pressure indicated on the pump label. When outlet pressure drops below a predetermined limit (typically 15-20 psi.[1-1.4 bar] less than the shut-off pressure), the switch will close and the pump will operate until the shut-off (high) pressure is achieved. The shut-off pressure is set to factory calibrated standards. See the motor label and Product Data Sheet for specific pump specifications.

CAUTION: Failures due to improper adjustment of the pressure switch will not be covered under the limited warranty. If the plumbing is restrictive or the flow rate is very low, the pump may re-pressurize the outlet faster than the fluid is being released causing rapid cycling (ON/OFF within 2 seconds). If the pump is subjected to rapid cycling during normal operation, or for infrequent periods, damage may occur. Applications which exhibit rapid cycling should have restrictions in the outlet minimized.

PLUMBING

- Flexible high pressure tubing compatible with the fluid should be used to connect the inlet/outlet ports. Tubing should be either 3/8” or 1/2” [10 or 13 mm] I.D., Allow for the shortest possible tubing route and avoid sharp bends that may kink over time.

NOTE: Restrictions on the inlet may cause vacuum levels to reach the fluid vapor pressure, causing cavitation, degassing, vapor lock and a loss in performance. Inlet pressure must not exceed 30 psi.[2.1 bar] maximum.

- 1/2” Male threaded models: Are intended to be used with SHURflo Swivel Barb Fittings which seal with an internal taper when hand tightened. Standard 1/2” NPT fittings may be used when tightened to a maximum torque of 3.7 ft\lb (45 in\lb) [5 Nm].

NOTE: SHURflo does not recommend the use of metal fittings or rigid pipe to plumb the inlet/outlet ports. Standard plastic male and female threaded are recommended.

CAUTION: Sealers and Teflon tape may act as lubricant causing cracked housings or stripped threads due to over tightening. Care should be used when applying sealers. Sealers may enter the pump inhibiting valve action, causing no prime or no shut-off. Failures due to foreign debris is not covered under warranty.

- Installation of a 50 mesh strainer is recommended to prevent foreign debris from entering the pump.

- If a check valve is installed in the plumbing, it must have a cracking pressure of no more than 2 psi [.14 bar].

Sprinkler System Operation

CAUTION: Circuit protection is dependent on the individual application requirements. Failure to provide proper overload / thermal devices may result in a motor failure, which will not be covered under warranty.

TROUBLESHOOTING

PUMP WILL NOT START:

- Check fuse or breaker
- Check For correct voltage ($\pm 10\%$) and electrical connections
- Check Pressure switch operation and correct voltage at switch or motor wires (as equipped).
- Check Rectifier or motor for open or grounded circuit
- Check For locked drive assembly

WILL NOT PRIME: (No discharge/Motor runs)

- Check Out of product
- Check Strainer for debris
- Check Inlet tubing/plumbing for severe vacuum leak
- Check Inlet/Outlet tubing severely restricted (kinked)
- Check Debris in pump inlet/outlet valves
- Check Proper voltage with the pump operating ($\pm 10\%$)
- Check Pump housing for cracks

LEAKS FROM PUMP HEAD OR SWITCH:

- Check For loose screws at switch or pump head.
- Check Switch diaphragm ruptured or pinched
- Check For punctured diaphragm if fluid is present at bottom drain

PUMP WILL NOT SHUT-OFF: (Pressure switch equipped)

- Check Output line closed and no leaks
- Check For air trapped in outlet line or pump head
- Check For correct voltage to pump ($\pm 10\%$)
- Check Inlet/Outlet valves for debris or swelling
- Check For loose drive assembly or pump head screws
- Check Pressure switch operation/adjustment incorrect refer to S/B
- Check #1031 for differential and pressure adjustment procedure

NOISY / ROUGH OPERATION:

- Check Mounting feet that are compressed to tight
- Check Does the mounting surface multiply noise (flexible)
- Check For loose pump head or drive screws
- Check Is the pump plumbed with rigid pipe causing noise to transmit

Maintenance

The Track Curry is a low maintenance product.

- Every 5-6 hours lightly grease the Drum Bearings. (One or two shots of grease.)
- Periodically check for loose bolts and tighten as required.

Storing

- Store in a dry place on blocks or wood if possible.
- Clean all dirt off and apply paint over bare metal to prevent rust.
- Drain lines and motor of any freezable liquid when storing over winter.

Bolt Torque

As used on this machine

- Bolt torque table shown below gives torque values for various bolts used.
- This chart is for non-lubricated threads.
- Replace with same strength bolt.

Torque Specifications. Torque values are identified by their head markings.

Diameter	SAE 2		SAE 5		SAE 8	
	<i>ft-lb</i>	<i>N.m</i>	<i>ft-lb</i>	<i>N.m</i>	<i>ft-lb</i>	<i>N.m</i>
"A"						
1/4	6	(8)	8	(11)	12	(16)
5/16	11	(15)	17	(24)	25	(33)
3/8	20	(27)	31	(42)	44	(59)
7/16	32	(43)	49	(67)	70	(95)
1/2	49	(66)	76	(105)	105	(145)
5/8	97	(130)	150	(205)	210	(285)
3/4	144	(195)	265	(360)	375	(510)
7/8	165	(225)	430	(585)	605	(820)
1	250	(340)	645	(875)	910	(1230)
1 1/8	355	(480)	795	(1080)	1290	(1750)
1 1/4	500	(680)	1120	(1520)	1820	(2460)
1 1/2	870	(1180)	1950	(2640)	3160	(4290)

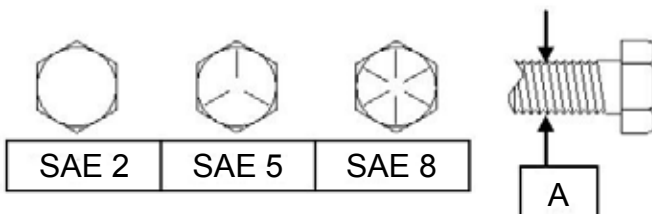

Allen head cap screw are similar to SAE 8 quality

These torques are for reference only. Not all these sizes and grades are necessarily used in this machine. Bolts that are used as a pivot or hinge have to be used with a locknut, therefore only tighten enough to secure the bolt and still allowing the part to rotate freely.



MK Martin Enterprise Inc.
3950 Steffler Rd Elmira, ON, Canada N3B 2Z3

Tel: 519-664-2752
Toll Free: 1-855-664-2752
Fax: 519-664-3695
E-mail: sales@mkmartin.ca
www.mkmartin.ca